

Vacuum Pump
Vacuum Solvent Recovery System
Vacuum Meter and Controller

Vacuum Pump

The ability to handle difficult and different vacuum challenges quickly.

Wiggins is your general laboratory companion and provides products that can be used in all kinds of laboratory environments. ChemVak is a product line in vacuum technology offering an extensive range of vacuum pumps for all applications. Including :



Chemical resistant diaphragm vacuum pumps which can be used in the chemical, pharmaceutical, petrochemical and other industries

Chemical resistant diaphragm pump
Frequency conversion chemical resistant vacuum pump



Chemical resistant diaphragm pump

Vacuum solvent recovery which can be used to get right vacuum conditions for various application



Vacuum Solvent recovery system



Oil-free piston vacuum pump, no pollution, no need for oil changes

Oil-free piston vacuum pump

Oil-sealed rotary vane vacuum pumps are widely used traditional vacuum pumps in research and production



Rotary vane vacuum pump



Vacuum pump selection guide

Before selecting a vacuum pump, please let us introduce a few basic concepts about vacuum.



▶ Vacuum

The degree of gas content in a vacuum state is usually expressed by the vacuum. The value read from the vacuum gauge is called the degree of vacuum. The vacuum value is the value that indicates that the actual value of the system pressure is lower than the atmospheric pressure. The value shown on the gauge is also called the gauge pressure, usually called the ultimate relative pressure. That is: Vacuum = atmospheric pressure - absolute pressure (atmospheric pressure is generally taken 1013.25mbar, the ultimate vacuum of the oil-free piston pump can reach about 30mbar, the ultimate vacuum of the chemical resistant diaphragm pump can reach 1mbar, and the ultimate vacuum of the rotary vane oil pump is about 0.0004mbar.



▶ Ultimate relative pressure

The relative pressure is how much lower the measured internal pressure is than the "atmospheric pressure", indicating that the actual value of the system pressure is lower than the value of atmospheric pressure. Since the air inside the container is pumped, the pressure inside the container is always lower than the pressure outside the container. Therefore, when using relative pressure or gauge pressure, the value must be preceded by a negative sign, indicating that the internal pressure of the container is lower than the external pressure.



▶ Ultimate absolute pressure

Absolute pressure refers to how much higher the measured internal pressure is than "theoretical vacuum (theoretical vacuum pressure value is 0Pa)". The object it compares is the absolute vacuum pressure value of the theoretical state. Due to technological limitations, we cannot pump the internal pressure to the absolute vacuum value of 0Pa in any case. Therefore, the vacuum value drawn by the vacuum pump is higher than the theoretical vacuum value. So when expressed in absolute vacuum, there is no negative sign in front of the value.



▶ Pumping speed

The pumping speed is a measure of the pumping speed of the vacuum pump. The general unit is expressed in L/min and m³/h. It is a parameter to make up for the air leakage rate. It is not difficult to understand, in theory, when pumping a container of the same volume, why is it easy for a vacuum pump with a large pumping capacity to pump the vacuum we need, while a vacuum pump with a small pumping capacity is so slow or even unable to pump the vacuum we want? Because It is always impossible for the pipeline or container to be absolutely air-free, and the large amount of air extraction makes up for the reduction of the vacuum degree caused by the air leakage, so the air volume can easily be pumped to the ideal vacuum value. It is suggested here that when the theoretical pumping capacity is calculated, we try to choose a vacuum pump with a higher pumping capacity. The specific calculation formula of the pumping volume will be introduced below.



After understanding the basic parameters of vacuum pumps such as vacuum degree, absolute pressure and relative pressure, we can enter the formal selection of vacuum pumps.



The required vacuum of the experimental process

The working pressure of the vacuum pump should meet the working pressure requirements of the process. The vacuum degree of the chemical resistant diaphragm pump should be half to an order of magnitude higher than the vacuum degree of the vacuum equipment. The vacuum must be at least 50mbar-10mbar), and the rotary vane oil pump must be an order of magnitude higher than the vacuum equipment.



The required pumping speed of the experimental process

The vacuum pump requires the pumping rate (that is, the ability of the vacuum pump to discharge gas, liquid, and solid under its working pressure), the general unit: m³/h, L/min, L/s, etc. The specific calculation method can refer to the following formula to calculate and select by yourself. Of course, the selection of vacuum pumps is a comprehensive process involving relevant experience and other factors.

$$S=(V/t) \times \ln(P1/P2)$$

S is the pumping rate of the vacuum pump (L/s)

V is the volume of the vacuum chamber (L)

t is the time required to reach the required vacuum (s)

P1 is the initial pressure (Pa)

P2 is the required pressure (Pa)



Determine the composition of the gas being pumped

- > 1- If the pumped object is gas, liquid or particles, if the pumped gas contains water vapor or a small amount of particles and dust and other impurities, carefully choose the rotary vane vacuum pump. If the vacuum degree is high, a filter device should be added. Only by filtering can the rotary vane vacuum pump be used as the vacuum obtaining equipment.
- > 2- Please let us know if the pumped object is corroded (acidic or alkaline, what is the pH value?). If the gas contains acid-base corrosion or organic corrosion, it should be filtered or neutralized to choose the rotary vane vacuum pump. If the vacuum meets the requirements for use, it is recommended to use an anti-corrosion diaphragm pump.
- > 3- If the pumped object contaminates rubber or oil? Corresponding vacuum equipment should be selected for different pumped media. If the gas contains a large amount of vapor, particles, and corrosive gas, it should be considered in the intake of the pump. Install the corresponding auxiliary equipment on the pipeline, such as condenser, filter, etc. (contact WIGGENS for details).
- > 4- If the noise and vibration of the vacuum pump have any influence.

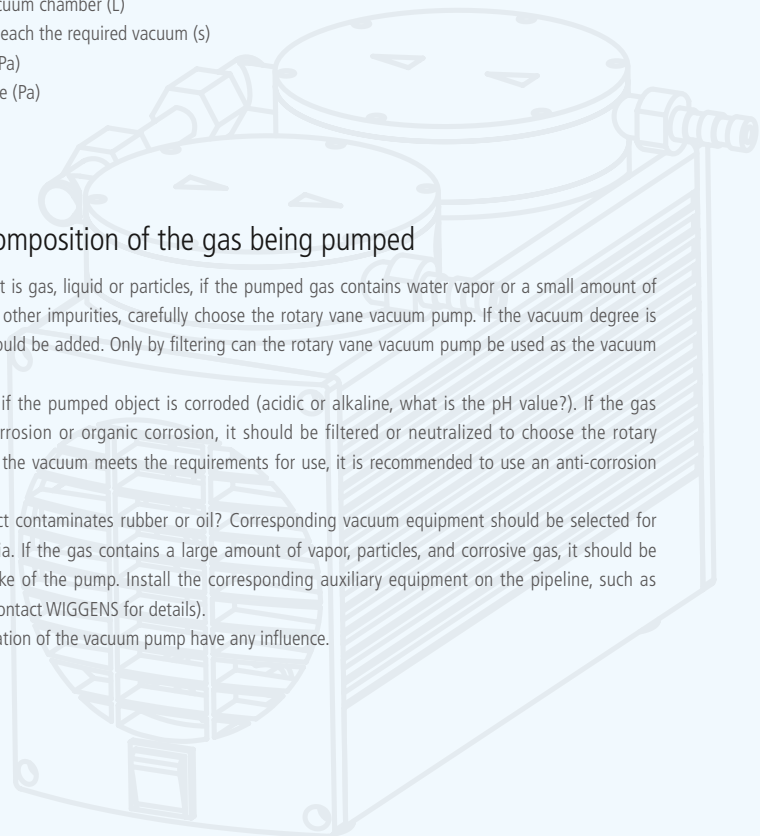

Application Guide

Application	Picture	Description	Pump speed / Vacuum	Recommended vacuum pump
Conventional vacuum requirements		Compact, portable, with certain corrosion resistance	25L/min 13mbar	A410
Vacuum filtration system		The filtered sample is non-corrosive	34L/min 100mbar	V400
		The filtered sample is corrosive and requires high corrosion resistance of the vacuum pump	34L/min 120mbar	C400
Glass vacuum dryer		It is recommended to use a chemical resistant diaphragm vacuum pump. In addition, a vacuum gauge and a vacuum regulating valve are also required	35L/min 13mbar	C420
Vacuum drying oven		The samples are usually aqueous, acidic or alkaline solutions, so chemical resistant diaphragm vacuum pumps are often recommended	37L/min 2-4mbar	C920Z
Vacuum centrifugal concentrator		The samples are usually aqueous, acidic or alkaline solutions, so chemical resistant diaphragm vacuum pumps are often recommended, the ultimate vacuum is only 1-2mbar	37L/min 2-4mbar	C920Z
		Rotary vane oil pump can reach extremely high vacuum, but it needs to be used with cold trap	180L/min 4×10^{-4} mbar	R-8D
Freeze dryer		Rotary vane oil pump is usually used, equipped with oil mist filter and cold trap	180L/min 4×10^{-4} mbar	R-8D

Application	Picture	Description	Pump speed / Vacuum	Recommended vacuum pump	
Rotary evaporator		0.5~3L evaporating flask, which requires high corrosion resistance of the vacuum pump, and usually needs to be used with a vacuum controller	35L/min 13mbar	C420	
		6~20L evaporating flask, which requires high corrosion resistance of the vacuum pump, and usually needs to be used with a vacuum controller	60L/min 2mbar	C960T	
		50~100L evaporating flask has high requirements for the corrosion resistance of the vacuum pump, and usually needs to be used with a vacuum controller	145L/min 8mbar	C2000T	
Multi-channel vacuum applications		Rotary vane oil pump can provide a large enough pumping rate, but it needs a matching cold trap	360L/min 4×10^{-4} mbar	R-24D	
Biochemical liquid suction pump		After biochemical culture, it is used to separate tissues from culture fluid	25~40L/min 100mbar	BioVac series	
Vacuum controller		Able to set and control the vacuum degree of the system	Vacuum control range: 0.1~1000mbar	DVR series	
Digital vacuum gauge		Able to display the vacuum degree of the system in real time	Vacuum measurement range: 0.1~1000mbar	VDM series	



New Entry Level for
Anti-Corrosion Diaphragm Pump



A410

A510

Chemical Resistant Diaphragm Pump (A Series)

- > Chemvak A series are chemical resistant diaphragm vacuum pumps which can be used in the chemical, pharmaceutical, petrochemical and other industries, such as suction filtration, vacuum distillation, rotary evaporator, vacuum concentration, centrifugal concentration, solid phase extraction and so on.
- > A series pumps can be widely used for hard acidic, basic and solvent vapors by utilizing corrosion proof PTFE on all the wetted surfaces. The vacuum chamber and the drive chamber are separated and sealed, ensuring a longer working life of mechanical components
- > Chemvak A series pumps are driven by diaphragm, without the need of lubricant, regular oil changes and maintenance; with no oil pollution.
- > Driven direct by motor with no additional belt-driven transmission; the quality vibration-proof assembly makes Chemvak A series run at the lowest noise level among all other equivalent pumps.
- > Cost-effective, reliable, unique structural design, noise less than 50dB.
- > A variety of models are available to meet the various needs of the laboratory, with a minimum vacuum of up to 8 mbar.
- > Every motor of Chemvak A series pumps has a built-in thermal protection device to shut off the pump automatically when overheated and then resume working when the temperature cools down.

Features

- > No pollution when working
- > Can be used for suction of high temperature steam or condensate
- > Overheat protection and power insurance
- > Chemical resistant design
- > Suitable for corrosive gases and steam media
- > Environmentally friendly design
- > Strong tightness

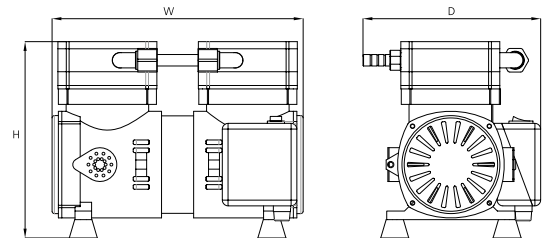

Model / Specifications	A410	A510
Order No.	170410	170510
Flow rate [m ³ /h] at atm. pressure	1.5	2.4
Flow rate [L/min] at atm. pressure	25	40
Ultimate vacuum [mbar abs.]	13	8
Max. Power P [W]	95	245
Max. current [A]	0.6	1
Motor speed [rpm]	1450	1450
Pump head	Double stage	Double stage
Hose connections [mm]	10	10
Noise [dB]	50	60
Dimensions W x D x H [mm]	230×155×173	290×190×210
Weight [kg]	4.5	10
Power supply	220V/50Hz	220V/50Hz

Chemical Resistant Diaphragm Pumps Flow curve

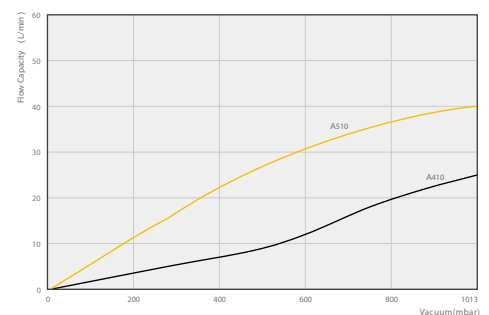

Note: Above data is based on the 220V/50Hz instrument



Chemical Resistant Diaphragm Pump (C Series)

C series construction with PTFE makes them very resistant to chemical vapors from inlet to exhaust and very tolerant to condensates. Pumping chambers are hermetical ensuring long lifetimes of mechanical parts.

Most importantly, diaphragm pumps are oil-free, with vastly reduced service demands compared with oil sealed pumps. They eliminate the cost of water and its contamination well-known from water-jet aspirators, and the waste-oil disposal of rotary vane pumps.

They are chemical resistant diaphragm vacuum pumps which can be widely used for hard acidic, basic and solvent vapors by utilizing corrosion proof PTFE on all the wetted surfaces. Through innovative mechanical technology and human considerations, we have made C series to be quiet, safe, maintenance-free and cost effective vacuum pumps.

Features

High chemical resistant

All wetted parts of C series pump are made of PTFE which is ideal for extremely aggressive / corrosive gases and vapors.

Long-term durable

Head cover and diaphragm made of PTFE/PTFE-coated with stability core for unsurpassed long-term performance

No air pollution, maintenance free

Chemvak C series pumps are driven by diaphragm, without the need of lubricant, regular oil changes and maintenance; with no oil pollution.

Practical

- > smooth surfaces for easy cleaning
- > sealing system provides reduced leakage rates for improved ultimate vacuum

Quiet and low vibration

Driven direct by motor with no additional belt-driven transmission; the quality vibration-proof assembly makes Chemvak C series run at the lowest noise level among all other equivalent pumps.

Thermal protection device

Every motor of Chemvak C series pumps has a built-in thermal protection device to shut off the pump automatically when overheated and then resume working when the temperature cools down.

International safety certification

CE certification

The stability core principle: for unprecedented long-term performance

chemistry diaphragm pumps provide optimum performance and unsurpassed service intervals even in harsh chemical applications. We achieve this unmatched reliability by manufacturing the most highly stressed components – the head cover and clamping disk.

- > high quality PTFE coated EPDM provides long term chemical resistance
- > this thick-walled, diffusion resistant, molded fluoroplastic is supported by a stable metallic core for durability
- > mechanical precision finishing ensures reproducible WIGGENS quality

Application

- > Chemical and petrochemical Industry
- > Pharma Industry
- > Filtration processes
- > Vacuum distillation
- > Rotary evaporation
- > Vacuum and centrifugal concentration
- > Solid phase extraction
- > Conventional drying and gel drying
- > Advanced substitute for water-jet pumps

Chemical Resistant Diaphragm Pumps Flow curve

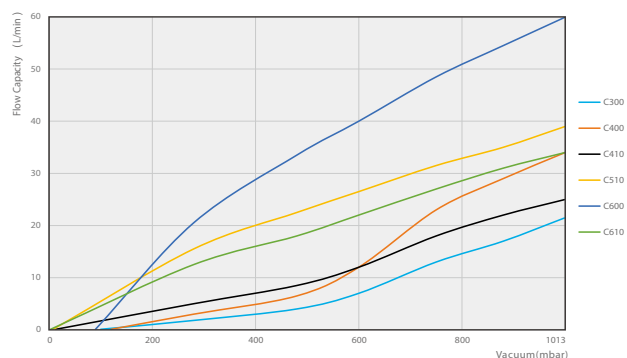

Note: Above data is based on the 220V/50Hz instrument

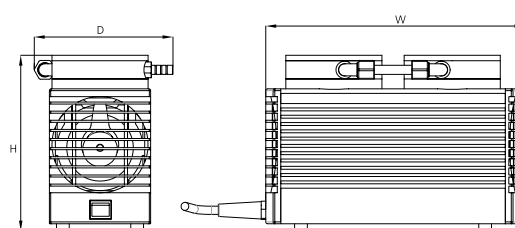

Vacuum display and control

Set 1

Order No. :169311-06
Included vacuum trap, regulator and vacuum gauge



Set 2

Order No.: 169312-06
Included vacuum trap, regulator and digital meter DVM150C



Set 3

Order No. : 900414-1 & 169313-06
Included vacuum trap, regulator, chemical resistant vacuum controller DVR480



Model / Specifications	C300	C400	C410	C420 NEW!	C510	C520 NEW!	C600	C602 NEW!	C610
Order No.	169300	169400	169410	169420	169510	169520	169600	169602	169610
Flow rate [m ³ /h] at atm. pressure	1.32	2.04	1.5	1.5	2.04	3.0	3.6	4.2	2.22
Flow rate [L/min] at atm. pressure	22	34	25	35	34	50	60	70	37
Ultimate vacuum [mbar abs.]	100	120	13	13	8	8	90	80	2~4
Max. Power P [W]	60	95	95	95	245	245	270	270	270
Motor speed [rpm]	1450	1450	1450	1450	1450	1450	1450	1450	1450
Pump head	Single stage	Single stage	Double stage	Double stage	Double stage	Double stage	Single stage	Single stage	Double stage
Hose connections [mm]	10	10	10	10	10	10	10	10	10
Noise [dB]	50	50	50	50	60	55	60	55	60
Dimensions W x D x H [mm]	233×110×210	294×156×195	294×156×195	294×156×195	380×156×226	380×156×226	380×162×226	380×156×226	380×171×226
Weight [kg]	6	8.5	8.5	8.5	13.2	14.5	13.2	14.5	13.8
Power supply	220V/50Hz	220V/50Hz	220V/50Hz	220V/50Hz	220V/50Hz	220V/50Hz	220V/50Hz	220V/50Hz	220V/50Hz

Chemical Resistant Diaphragm Pump

Fast pumping speed

C900 series chemical resistant diaphragm pumps are ideally suited for pumping aggressive gases and vapors in a vacuum range down to 1mbar and pumping speed up to 95L/min

Features

- > All wetted parts are made of chemical resistant materials
- > Fast pumping speed
- > Low noise
- > Overheat protection
- > Vacuum can be controlled by manual valve, vacuum controller
- > Easy and convenient for maintenance



The motor drives the pump head to vacuum

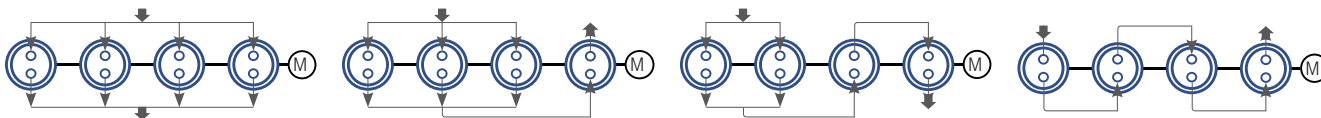

C900E with single stage of pump head

C920Z with double stage of pump head

C960T with Triple stage of pump head

C980V with quadruple stage of pump head

Order No. :169311-06

Included vacuum trap, regulator and vacuum gauge

Set 1



Order No.: 169312-06

Included vacuum trap, regulator and digital meter DVM150C

Set 2



Order No. : 900414-1 & 169313-06

Included vacuum trap, regulator, chemical resistant vacuum controller DVR480

Set 3



Model / Specifications	C900E	C920Z	C960T	C980V
Order No.	169900	169920	169960	169980
Flow rate [m ³ /h] at atm. pressure	5.7	4.5	3.6	2.4
Flow rate [L/min] at atm. pressure	95	75	60	40
Ultimate vacuum [mbar abs.]	< 30	< 8	< 2	< 1
Max. Power P [W]	370	370	370	370
Motor speed [rpm]	1425	1425	1425	1425
Pump head	Single stage	Double stage	Triple stage	Quadruple stage
Hose connections [mm]	10	10	10	10
Noise [dB]	50	50	50	50
Dimensions W x D x H [mm]	440×270×240	440×270×240	440×270×240	440×270×240
Weight [kg]	21.5	21.5	21.5	21.5
Power supply	220V/50Hz	220V/50Hz	220V/50Hz	220V/50Hz

Chemical Resistant Diaphragm Pump

Variable-frequency vacuum pump, fast pumping speed

Chemical resistant diaphragm pumps are ideally suited for pumping aggressive gases and vapors in a vacuum range down to 1mbar. and pumping speed up to 95L/min

The variable-frequency pump needs to be connected with the variable-frequency controller to control the vacuum by adjusting the speed of the motor, which is especially suitable for the vacuum control of large-capacity system. It not only ensures a faster pumping speed, but also obtains a stable vacuum.

Features

- > All wetted parts are made of chemical resistant materials
- > Variable frequency motor for fast pumping speed
- > Low noise
- > Overheat protection
- > Vacuum can be controlled by manual valve, vacuum controller or variable frequency controller
- > Easy and convenient for maintenance



Variable-frequency vacuum pump W/O frequency controller

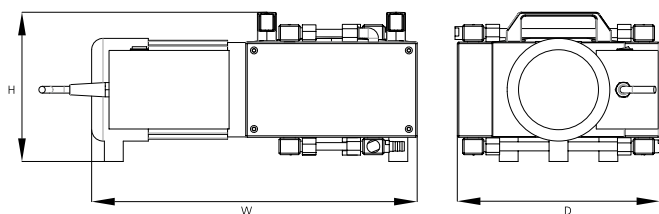

Variable-frequency vacuum pump W/ frequency controller

The motor drives the pump head to vacuum

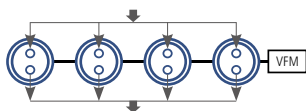

C900EF with variable frequency motor and single stage of pump head

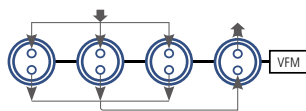

C920ZF with variable frequency motor and double stage of pump head

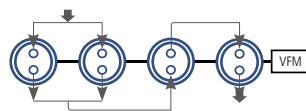

C960TF with variable frequency motor and triple stage of pump head

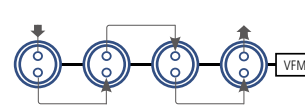

C980VF with variable frequency motor and quadruple stage of pump head

Model / Specifications	C900EF	C920ZF	C960TF	C980VF
Order No. (W/O frequency controller)	169900B	169920B	169960B	169980B
Order No. (W/ frequency controller)	169901B	169921B	169961B	169981B
Flow rate [m ³ /h] at atm. pressure	5.7	4.5	3.6	2.4
Flow rate [L/min] at atm. pressure	95	75	60	40
Ultimate vacuum [mbar abs.]	< 30	< 8	< 2	< 1
Max. Power P [W]	370	370	370	370
Motor speed [rpm]	0~1380/0~1680 ¹⁾	0~1380/0~1680 ¹⁾	0~1380/0~1680 ¹⁾	0~1380/0~1680 ¹⁾
Pump head	Single stage	Double stage	Triple stage	Quadruple stage
Hose connections [mm]	10	10	10	10
Noise [dB]	50	50	50	50
Dimensions W x D x H [mm]	440×270×240	440×270×240	440×270×240	440×270×240
Weight [kg]	21.5	21.5	21.5	21.5
Variable frequency vacuum controller	Order separately	Order separately	Order separately	Order separately
Power supply	200 - 240V, 50/60Hz	200 - 240V, 50/60Hz	200 - 240V, 50/60Hz	200 - 240V, 50/60Hz

¹⁾ means the motor speed range of 50Hz and 60Hz models respectively

Frequency Conversion Chemical Resistant Vacuum Systems

Integrated variable frequency controller

- > A new generation of intelligent vacuum technology, modular design, integrated variable frequency pumps and control units, compact design, light weight. It can adjust the speed of the diaphragm pump by frequency conversion motor and controller, controlling the vacuum pressure more accurately.
- > PID Self-tuning for vacuum control, the controller automatically changes the PID value according to the artificial intelligence logic algorithm, accurately adjusting the motor speed and stabilizing the precise vacuum degree.
- > This series of chemical resistant vacuum pumps are suitable for the treatment of corrosive gases in the chemical, pharmaceutical, petrochemical and other industries, such as extraction, vacuum distillation, rotary evaporator, vacuum concentration, centrifugal concentration, solid phase extraction and other uses.
- > All parts in contact with gas and condensate are made of high-quality PTFE. The gas chamber and drive chamber are separated and sealed to ensure a long life of the mechanical parts
- > Overheat protection, automatic shutdown when the temperature is too high, and automatic start when it goes back to the normal temperature, to ensure the security and stability of the system.

Features

- > Vacuum stability, easy to control, high control precision
- > Excellent chemical and vapour resistance
- > In the high vacuum degree, the performance is still very good.
- > Long life, simple and convenient for maintenance.
- > Simple and convenient to work in a stable and lasting way
- > Small structural size, energy conservation and environmental protection
- > High level of protection for motor, suitable for various environments

Application

- > Vacuum distillation for large volume
- > Large capacity reaction kettle
- > Large capacity vacuum filtration
- > Vacuum enrichment
- > Vacuum drying
- > Various applications in the semiconductor industry



Standard Configuration:
The vacuum system integrated variable frequency controller, and also includes vacuum trap, regulator and vacuum gauge (Order No. 169311-06)

Model / Specifications	C900EEF	C920ZEF	C960TEF	C980VEF
Order No.	169900C	169920C	169960C	169980C
Flow rate [m ³ /h] at atm. pressure	5.7	4.5	3.6	2.4
Flow rate [L/min] at atm. pressure	95	75	60	40
Ultimate vacuum [mbar abs.]	< 30	< 8	< 2	< 1
Vacuum setting range [mbar abs.]	0.1~1000	0.1~1000	0.1~1000	0.1~1000
Max. Power P [W]	400	400	400	400
Motor speed [rpm] @50Hz	0~1380	0~1380	0~1380	0~1380
Motor speed [rpm]@60Hz	0~1680	0~1680	0~1680	0~1680
Pump head	Single stage	Double stage	Triple stage	Quadruple stage
Hose connections [mm]	10	10	10	10
Noise [dB]	50	50	50	50
Dimensions W x D x H [mm]	220×400×495	220×400×495	220×400×495	220×400×495
Weight [kg]	21.5	21.5	21.5	21.5
Power supply	200 - 240V, 50/60Hz	200 - 240V, 50/60Hz	200 - 240V, 50/60Hz	200 - 240V, 50/60Hz

Chemical Resistant Diaphragm Pump

Fast pumping speed for industrial applications

C1200 series chemical resistant diaphragm pumps are ideally suited for pumping aggressive gases and vapors in a vacuum range down to 1mbar and pumping speed up to 120L/min.

Features

- > All wetted parts are made of chemical resistant materials
- > Fast pumping speed
- > Low noise
- > Overheat protection
- > Vacuum can be controlled by manual valve, vacuum controller
- > Easy and convenient for maintenance



The motor drives the pump head to vacuum

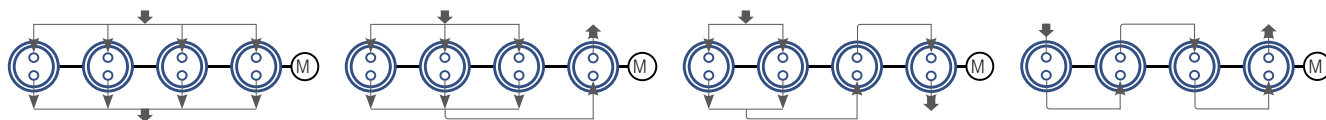

C1200E with single stage of pump head

C1200Z with double stage of pump head

C1200T with triple stage of pump head

C1200V with quadruple stage of pump head

Model / Specifications	C1200E	C1200Z	C1200T	C1200V
Order No.	W1031201	W1031202	W1031203	W1031204
Flow rate [m ³ /h] at atm. pressure	7.2	5.7	4.2	3
Flow rate [L/min] at atm. pressure	120	95	70	50
Ultimate vacuum [mbar abs.]	< 80	< 8	< 2	< 1
Max. Power P [W]	370	370	370	370
Max. current [A]	2	2	2	2
Motor speed [rpm]	1380	1380	1380	1380
Pump head	Single stage	Double stage	Triple stage	Quadruple stage
Hose connections of inlet	KF25 ¹⁾	KF25 ¹⁾	KF25 ¹⁾	KF25 ¹⁾
Hose connections of outlet	G1/2 ¹⁾	G1/2 ¹⁾	G1/2 ¹⁾	G1/2 ¹⁾
Noise [dB]	50	50	50	50
Dimensions W x D x H [mm]	440×270×240	440×270×240	440×270×240	440×270×240
Weight [kg]	21.5	21.5	21.5	21.5
Power supply	220~240V/50Hz	220~240V/50Hz	220~240V/50Hz	220~240V/50Hz

1) Included : 2 barbed fittings for tubing 16 mm inner dia.

Chemical Resistant Diaphragm Pump

Fast pumping speed for industrial applications

C2000 series chemical resistant diaphragm pumps are ideally suited for pumping aggressive gases and vapors in a vacuum range down to 1mbar and pumping speed up to 245L/min.

Features

- > All wetted parts are made of chemical resistant materials
- > Fast pumping speed
- > Low noise
- > Overheat protection
- > Vacuum can be controlled by manual valve, vacuum controller
- > Easy and convenient for maintenance



The motor drives the pump head to vacuum

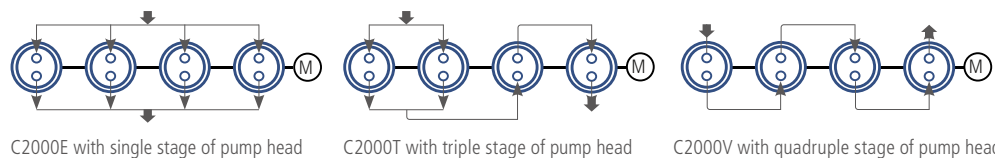

Model / Specifications	C2000E	C2000T	C2000V
Order No.	W1032001	W1032002	W1032003
Flow rate [m ³ /h] at atm. pressure	14.7	10.8	9.0
Flow rate [L/min] at atm. pressure	245	180	150
Ultimate vacuum [mbar abs.]	< 70	< 2	< 1
Max. Power P [W]	750	750	750
Motor speed [rpm]	1380	1380	1380
Pump head	Single stage	Triple stage	Quadruple stage
Hose connections of inlet	KF25 ¹⁾	KF25 ¹⁾	KF25 ¹⁾
Hose connections of outlet	G1/2 ¹⁾	G1/2 ¹⁾	G1/2 ¹⁾
Noise [dB]	60	60	60
Dimensions W x D x H [mm]	615×285×386	615×285×386	615×285×386
Weight [kg]	41	41	41
Power supply	220~240V/50Hz	220~240V/50Hz	220~240V/50Hz

1) Included : 2 barbed fittings for tubing 16 mm inner dia.

Chemical Resistant Diaphragm Pump

Variable-frequency vacuum pump, fast pumping speed

Chemical resistant diaphragm pumps are ideally suited for pumping aggressive gases and vapors in a vacuum range down to 1mbar.

Features

- > All wetted parts are made of chemical resistant materials
- > Variable frequency motor for fast pumping speed
- > Low noise
- > Overheat protection
- > Vacuum can be controlled by manual valve, vacuum controller or variable frequency controller
- > Easy and convenient for maintenance



The motor drives the pump head to vacuum

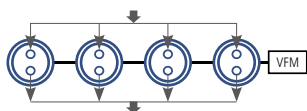

C2000EEF with variable frequency motor and single stage of pump head

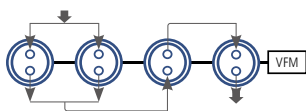

C2000TEF with variable frequency motor and triple stage of pump head

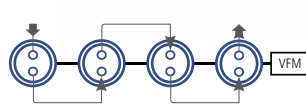

C2000VEF with variable frequency motor and quadruple stage of pump head

The variable-frequency pump needs to be connected with the variable-frequency controller to control the vacuum by adjusting the speed of the motor, which is especially suitable for the vacuum control of large-capacity system. not only ensures a faster pumping speed, but also obtains a stable vacuum.

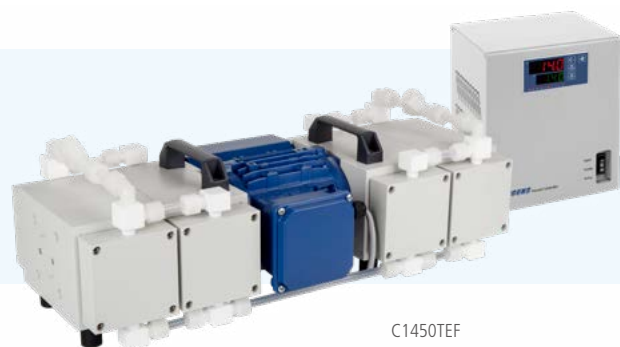

C1450TEF

Model / Specifications	C2000EEF	C2000TEF	C2000VEF	C1450TEF
Order No. (W/ frequency controller)	W1032011	W1032012	W1032013	1691450C
Flow rate [m ³ /h] at atm. pressure	16.2	12.6	9.6	
Flow rate [L/min] at atm. pressure	270	210	160	145
Ultimate vacuum [mbar abs.]	< 70	< 2	< 1	< 8
Max. Power P [W]	750	750	750	600
Motor speed [rpm]	0~1380	0~1380	0~1380	0~1400
Pump head	Single stage	Triple stage	Quadruple stage	Triple stage
Hose connections of inlet	KF25 ¹⁾	KF25 ¹⁾	KF25 ¹⁾	10mm
Hose connections of outlet	G1/2 ¹⁾	G1/2 ¹⁾	G1/2 ¹⁾	G1/2
Noise [dB]	60	60	60	65
Dimensions W x D x H [mm]	615×285×386	615×285×386	615×285×386	635×280×200
Weight [kg]	41	41	41	36.5
Power supply	200 - 240V, 50/60Hz	200 - 240V, 50/60Hz	200 - 240V, 50/60Hz	200 - 240V, 50/60Hz

1) Included : 2 barbed fittings for tubing 16 mm inner dia.

Vacuum Solvent Recovery System

This chemistry vacuum system has a wide range of applications like evacuation, evaporation and pumping of gases and vapors in chemical, biological and pharmaceutical laboratories. This system is ideal for high vacuum requirements with high boiling solvents. Typical applications are rotary evaporators and drying ovens.

The separator at the inlet, made of glass with a protective coating, retains particles and liquid droplets.

The waste vapor condenser at the outlet is highly efficient and compact. The condenser enables efficient recycling of solvents and active protection of the environment outstanding chemical resistance and superior vapor tolerance

- > exceptionally high performance even at low vacuum
- > excellent ultimate vacuum even with gas ballast
- > whisper quiet and very low vibration
- > excellent environmental friendliness due to efficient solvent recovery

- > Sealed system to enable a good distillation environment
- > Precise control of the evaporation process
- > Compact and environmental friendly design
- > Low noise

- > Buffer bottle prevents particles from damaging the pump
- > Direct electric connection
- > Ultimate vacuum range: 1-30 mbar
- > Flow rate range: 25-95 L/min

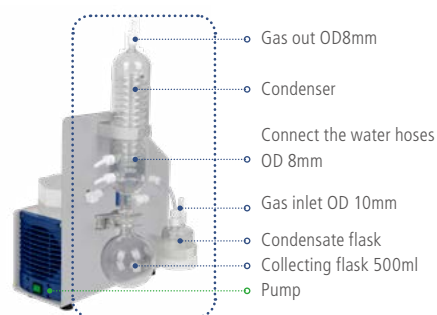

CSH System

The inlet of the CSH System is connected to a segregation bottle, whereas the outlet is connected to a condenser, which is used to condensate and recover the solvent.

Model	CSH410	CSH510	CSH520 NEW!	CSH610
Build in Pump Type	C410	C510	C520	C610
Power (W)	95	245	150	245
Ultimate Vacuum (mbar)	13	8	8	2
Max. Flow Rate (L/min)	25	34	50	34
Outlet Size (outer diameter in mm)	10	10	10	10
Dimensions W x D x H [mm]	341*255*545	341*255*545	341*255*545	341*255*545
Weight (kg)	12.5	15.8	17.1	16.6
Order No.	900512	900513	900515	900514



CSH System
Includes chemical resistant diaphragm pump, separator, condenser, tubing

CSC System

The inlet of the CSC System is connected to a segregation flask, whereas the outlet is connected to a condenser, which is used to condensate and recover the solvent. In addition, the system contains a vacuum controller to set, display, and control the vacuum.

Fully automated vacuum generation system comprising chemical resistant diaphragm vacuum pump, base plate, high performance condenser, segregation flask, vacuum control device and valves.

Model	CSC410	CSC510	CSC520 NEW!	CSC610
Build in Pump Type	C410	C510	C520	C610
Power (W)	95	245	150	245
Ultimate Vacuum (mbar)	13	8	8	2
Max. Flow Rate (L/min)	25	34	50	34
Outlet Size (outer diameter in mm)	10	10	10	10
Dimensions W x D x H [mm]	341*255*545	341*255*545	341*255*545	341*255*545
Weight (kg)	16	19.3	20.6	20.1
Order No.	900522	900523	900525	900524



CSC System
Includes chemical resistant diaphragm pump, vacuum controller, separator, condenser, tubing

CSC Systems (Frequency conversion model)

- > New generation of intelligent vacuum technology, modular design, integrated variable frequency pumps and control units, compact design, light weight.
- > PID Self-tuning for vacuum control, the controller automatically changes the PID value according to the artificial intelligence logic algorithm, accurately adjusting the motor speed to get the precise vacuum value.
- > All parts in contact with gas and condensate are made of high-quality PTFE. The gas chamber and drive chamber are separated and sealed to ensure a long life of the mechanical parts
- > It can be directly connected to the power supply and working system.
- > Recovery flasks at air inlet to prevent solid particles and liquid water from entering the pump chamber.

Model	CSC900E	CSC920Z	CSC960T	CSC980V
Power (W)	400	400	400	400
Resolution (mbar)	0.1	0.1	0.1	0.1
Setting range (mbar)	0.1-1000	0.1-1000	0.1-1000	0.1-1000
Max. vacuum (mbar)	< 30	< 8	< 2	< 1
Max. Flow Rate (L/min)	95	75	60	40
Outlet (mm)	10	10	10	10
Dimensions W x D x H [mm]	220*400*495	220*400*495	220*400*495	220*400*495
Weight (kg)	25	25	25	25
Noise Level (dB)	50	50	50	50
Order No.	900532	900533	900534	900535



CSC System (Frequency conversion)
Includes chemical resistant diaphragm pump, variable frequency controller, separator, condenser, tubing

Chemical Resistant Vacuum Controller

- > Wide measurement and control range
- > Control the vacuum down to 0.1 mbar
- > Up to 5-step program control
- > All parts that come into contact with gases and vapors are made of PTFE or highly durable ceramic to ensure high chemical resistance
- > Bright LED display and convenient on-touch control
- > RS-232 and analog connection available
- > Pressure release feature for easy vacuum system installation
- > Direct electric control of the vacuum pump
- > Energy saving and environmental friendly
- > Suitable for continuous operation

Specifications

Model	DVR480	DVR480-Pro
Order No.	900414-1	900414-2
Voltage	100-240V, 50/60Hz	100-240V, 50/60Hz
Displayed Vacuum Accuracy (mbar)	0.1	0.1
Controllable Range (mbar)	0.1...1000	0.1...1000
Measurement Accuracy	0.25%FS	0.1%FS
Display	LED	LED
Control Mode	On-Touch	On-Touch
Timer / Program	Yes / Up to 5 Steps	Yes / Up to 5 Steps
Pressure Release Feature	Yes	Yes
Electrical Control of the Pump	Yes	Yes
Protection Category	IP40	IP40
Corrosion resistance	All parts that come into contact with gases are made of PTFE or highly durable ceramic to ensure the resistance to various acid, base, or organic solvent gases.	



DVR480

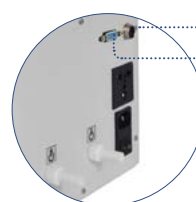

..... Analog Signal Input and Output Port
..... RS-232 / RS-485, Modbus

Accessories For Chemical Resistant Diaphragm Pumps

General Purpose Valves

A range of plug valves for applications with demand for pressure and temperature, with max. pressure at 1 bar and max. vacuum at 7mbar.

Note: Rapid changes in temperature in excess of 25°C /min may cause these valves to leak due to the expansion properties of PTFE. It can be sterilised at 135°C .

Straight Through Bayonet

Order No.	Outer Diameter [mm]	Inner Diameter [mm]
016.702.5.2	4.5	2
016.702.2	6.0	2
016.703.7.2	6.8	3
016.703.2	8.0	3
016.704.9.2	9.0	4
016.704.2	10.0	4
016.705.2	11.0	5
016.706.2	16	10



Straight Through Screw

Order No.	Outer Diameter [mm]	Inner Diameter [mm]
016.1202.6.2	6	2
016.1203.2	8	3
016.1204.2	8	4



T-Shape Bayonet

Order No.	Outer Diameter [mm]	Inner Diameter [mm]
016.802.5.2	4.5	2
016.802.2	6.0	2
016.803.7.2	6.8	3
016.803.2	8.0	3
016.804.9.2	9.0	4
016.804.2	10.0	4
016.805.2	11.0	5



T-Shape Screw

Order No.	Outer Diameter [mm]	Inner Diameter [mm]
016.1302.6.2	6	2
016.1303.2	8	3
016.1304.2	8	4



Straight Through Connector

Order No.	Outer Diameter [mm]	Inner Diameter [mm]
016.902.5.2	4.5	2
016.902.2	6.0	2
016.903.7.2	6.8	3
016.903.2	8.0	3
016.904.9.2	9.0	4
016.904.2	10.0	4
016.905.2	11.0	5
016.907.2	16	10

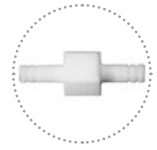

L-Shape Connector

Order No.	Outer Diameter [mm]	Inner Diameter [mm]
016.1002.5.2	4.5	2
016.1002.2	6.0	2
016.1003.7.2	6.8	3
016.1003.2	8.0	3
016.1004.9.2	9.0	4
016.1004.2	10.0	4
016.1005.2	11.0	5
016.1006.2	16	10



T-Shape Connector

Order No.	Outer Diameter [mm]	Inner Diameter [mm]
016.1102.5.2	4.5	2
016.1102.2	6.0	2
016.1103.7.2	6.8	3
016.1103.2	8.0	3
016.1104.9.2	9.0	4
016.1104.2	10.0	4
016.1105.2	11.0	5
016.1106.2	16	10



4-Way Connector

Order No.	Outer Diameter [mm]	Inner Diameter [mm]
016.1112.5.2	4.5	2
016.1112.2	6.0	2
016.1113.7.2	6.8	3
016.1113.2	8.0	3
016.1114.9.2	9.0	4
016.1114.2	10.0	4
016.1115.2	11.0	5
016.1116.2	16	10



Accessories For Chemical Resistant Diaphragm Pumps

PTFE Connector

Order No.	Description
C410015	Barbed fitting for tubing 10mm ID, M10x1, suitable for C300 / 400 / 500 / 600 / 900 series



PTFE Connector with O-ring

Adapter

Order No.	Description
C410055	KF25 to M10x1, suitable for C300 / 400 / 510 / 600 / 900 series
C410056	Barbed fitting for tubing 12mm ID, KF25, suitable for C1200 / 2000 series
C410057	Barbed fitting for tubing 19mm ID, KF25, suitable for C1200/2000 series
C410058	Barbed fitting for tubing 25mm ID, KF25, suitable for C1200 / 2000 series



C410055

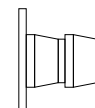

C410056

Silencer

The use of silencer will slightly effect the flow rate.

Order No.	Description
C900E030	Suitable for chemical resistant diaphragm pumps



Silencer

Diaphragm and Valve Plate Sets

Suitable for	diaphragm	valve plates	Number of pump heads *
C300	C410005	C510013	1
C320	C2000005	C2000013	1
C400/410	C410005	C510013	2
C510/600/610/	C510011	C510013	2
C320/420/402/520/602	C2000005	C2000013	2
C 900E/Z/T/V	C510011	C510013	4
C1200 E/Z/T/V	C2000005	C2000013	4
C2000 E/Z/T/V	C2000005	C2000013	8

*Notes. Replacement of consumables for one pump head requires replacement of one diaphragm and two valve platess



Diaphragm



Valve Plate

Diaphragm and valve plates set

Order No.	Description
410001	Diaphragm and valve plates set, Suitable for C300/400/410, Included: 1 diaphragm, 2 valve plates
510001	Diaphragm and valve plates set, Suitable for C500/510/600/610/900, Included: 1 diaphragm, 2 valve plates
1200001	Diaphragm and valve plates set, Suitable for 420/520/602/C1200/C2000, Included: 1 diaphragm, 2 valve plates



Diaphragm and valve plates set

Tubing

Order No.	Outer Diameter, mm	Inner Diameter, mm	Thickness, mm	Length, m
PTFE Tubing				
016.1706.01	6	4	1	1
016.1708.01	8	6	1	1
016.1712.01	12	10	1	1
016.1714.01	14	12	1	1
016.1716.01	20	18	1	1
016.1718.01	28	25	1.5	1
Viton Tubing				
168000-01	12	6	3	1
168001-01	14	8	3	1
168002-01	16	10	3	1
168003-01	18	12	3	1
168004-01	25	19	3	1
168005-01	31	25	3	1

Length upon request (min. 1 m)



PTFE Tubing



Viton Tubing

Chemical Resistant Vacuum Regulator / Filter Equipment

Order No.	Description
169311-06	Set 1 (Includes vacuum trap, regulator and vacuum gauge)
169312-06	Set 2 (Includes vacuum trap, regulator and digital meter DVM150C)
169313-06	Basic model without vacuum gauge, includes vacuum trap and regulator

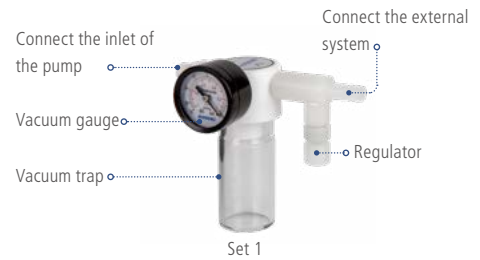

Set 1

Part	Material	Part	Material
Pressure Regulating Valve	PVDF	Filter Bottle	Borosilicate Glass
Filter cartridge	PTFE	Adapter	PTFE
Filter Bracket	ABS	Vacuum Sensor	Stainless Steel



Set 2

Digital Vacuum Meter

- > Designed for chemical resistant diaphragm pumps
- > Compact design, flange connector, strong tightness
- > TFT high brightness screen, easy for observation from multiple angles or long distance
- > Can be directly connected to vacuum pump by flange connection

Models	DVM150C
Voltage	100-240V, 50/60Hz
Display screen	High brightness TFT
Display resolution	0.1-1000mbar
Testing range	0-1000mbar
Material of sensor	Ceramic
Material for contact parts of the gas	PTFE and Ceramic
Connection	KF25 or 1/4NPT female
Size of the meter	100*65*55mm
Order No.	15060-01



DVM150C

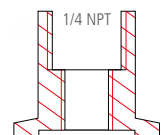

KF25

Application Guide

For rotary evaporator



Pump models	Max. vacuum (mbar)	Flow Rate (L/min)	Suitable for
C420	13 mbar	35L/min	1L / 2.5L
C520	8 mbar	50 L/min	5L
C600	90 mbar	60 L/min	10L
C610	2 mbar	34 L/min	5L
C920Z	8 mbar	75 L/min	50L,100L

For vacuum oven



Pump models	Max. vacuum (mbar)	Flow Rate (L/min)	Suitable for
C420	13 mbar	35L/min	15L
C520	8 mbar	50 L/min	45L
C600	90 mbar	60 L/min	60L
C610	2 mbar	34 L/min	30L

For vacuum centrifugal concentrator



Pump models	Max. vacuum (mbar)	Flow Rate (L/min)
C420	13mbar	35L/min
C520	8 mbar	50 L/min
C600	90 mbar	60 L/min
C610	2 mbar	34 L/min

For vacuum freeze dryer



Pump models	Max. vacuum (mbar)	Flow Rate (L/min)
R-8D	4×10^{-4} mbar	180 L/min
R-17D	4×10^{-4} mbar	283 L/min
R-24D	4×10^{-4} mbar	360 L/min
R-36D	4×10^{-4} mbar	540L/min

Oil-Free Piston Vacuum Pump

Chemvak V series vacuum pump is a piston-powered, oil-free pump. With innovative electronic, mechanical technology and human design concept, compact and light weight, clean and maintenance free, safe and comfortable.

Features

No air pollution, maintenance free

Chemvak V series pumps are driven by piston, without the need of lubricant, regular oil changes and maintenance; with no oil pollution.

Moisture trap with filter cartridge

Chemvak V series pumps are equipped with filter cartridge in air inlet to filter particle and moisture to prolong the life of pump.

Oil-free

The oil-free piston vacuum pump provides continuous, reliable, high flow vacuum for your container.

Vacuum regulator

Chemvak V series pumps are equipped with vacuum regulator to adjust vacuum.

Thermal protection device

Every motor of Chemvak V series pumps has a built-in thermal protection device to shut off the pump automatically when overheated and then resume working when the temperature cools down.

Application

- > Biology laboratories
- > Food industry
- > Microbiological detection
- > Vacuum extraction
- > Liquid filtration
- > Vacuum drying
- > Suspended solids measurement

Oil-Free Piston Vacuum Pumps flow curve

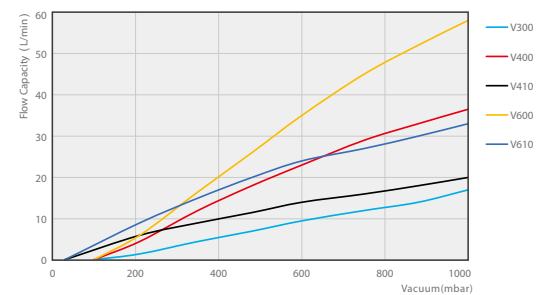

Note: Above data is based on the 220V/50Hz instrument

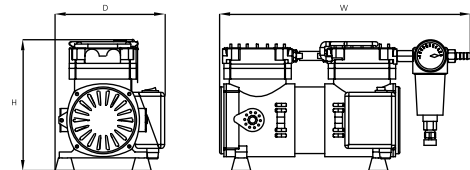

V300

V400

V410

V430

V600 / V610

V800 / V810

Model / Specifications	V300DC	V300	V400	V410	V430	V600	V610	V800	V810
Order No.	167330	167300	167400	167410	167430	167600	167610	167800	167810
Flow rate [m ³ /h] at atm. pressure	1.02	1.02	2.04	1.14	1.68	3.6	2.4	4.8	3
Flow rate [L/min] at atm. pressure	17	17	34	19	28	60	40	80	50
Ultimate vacuum [mbar abs.]	150	100	100	30	150/5500	120	30	100	30
Max. Power P [W]	35	60	80	80	125	190	210	220	220
Max. current [A]	3	0.3	0.4	0.4	0.6	1	1	1	1
Motor speed [rpm]	1450	1450	1450	1450	1450	1450	1450	1450	1450
Hose connections [mm]	9	9	9	9	9	9	9	9	9
Noise [dB]	50	50	60	50	50	52	65	75	75
Dimensions W x D x H [mm]	272x142x165	272x142x165	310x152x165	310x152x165	247x235x200	350x170x195	350x170x195	350x170x195	350x170x195
Weight [kg]	4.4	4.4	5.4	5.4	5.5	8.6	8.6	8.6	8.6
Power supply	DC12	220V/50Hz	220V/50Hz	220V/50Hz	220V/50Hz	220V/50Hz	220V/50Hz	220V/50Hz	220V/50Hz

Accessories For Oil-Free Piston Pumps

Connector

Description	Suitable for	Order No.
Connectors		
Outlet Diameter 9.5 mm	Oil-Free Piston Pumps	167300-20
Outlet Diameter 8 mm	Oil-Free Piston Pumps	167300-21
Outlet Diameter 6.4 mm	Oil-Free Piston Pumps	167300-26
Outlet Diameter 4.8 mm	Oil-Free Piston Pumps	167300-23
Outlet Diameter 3.2 mm	Oil-Free Piston Pumps	167300-24



L-Shape Connector

Outlet Diameter 8 mm	Oil-Free Piston Pumps	167300-25
----------------------	-----------------------	-----------



Quick Connection Outlet

Outlet Diameter 12 mm	Oil-Free Piston Pumps	168100-12
Outlet Diameter 10 mm	Oil-Free Piston Pumps	168100-10
Outlet Diameter 8 mm	Oil-Free Piston Pumps	168100-08
Outlet Diameter 6 mm	Oil-Free Piston Pumps	168100-06
Outlet Diameter 4 mm	Oil-Free Piston Pumps	168100-04



Silencer

Description	Suitable for	Order No.
Silencer	V300/400/410/V430	167300-42
Silencer	V600/610/V800/V810	167600-42



Tubing

Outer Diameter mm	Inner Diameter mm	Thickness mm	Length m	Suitable for	Order No.
PER Tubes					
6	4	1	1	A,C,V Pumps	168010-01
8	6	1	1	A,C,V Pumps	168011-01
10	8	1	1	A,C,V Pumps	168012-01
12	10	1	1	A,C,V Pumps	168013-01
Silicon Tubes					
12	6	3	1	V Pumps	168020-01
14	8	3	1	V Pumps	168021-01
16	10	3	1	V Pumps	168022-01

Length upon request (min. 1m)

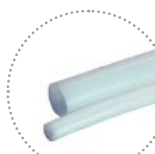

Foot switch

Description	Suitable for	Order No.
Foot switch	Applicable to C and V Series Vacuum Pumps	167200-41



Non-Chemical-Resistant Filtration Device

Description	Suitable for	Order No.
Non-Chemical-Resistant Filtration Device Set 1(incl. pressure gauge)	V300/400/410/V430	167300-05
Non-Chemical-Resistant Filtration Device Set 1(incl. pressure gauge)	V600/610/V800/V810	167300-06



Rotary Vane Vacuum Pump

Oil-sealed Rotary Vane vacuum pumps are widely used traditional vacuum pumps in research and production, which can be used independently, or serve as backing pumps for molecular pumps or diffusion pumps. Wiggins' direct driven rotary vane pumps are available as one and two-stage versions, covering the range from desktop lab pumps to production line pumps, with low noise and stable working temperature for common voltages and frequencies, long lifespan, and outstanding reliability for chemical applications. Various application areas may include vacuum distillation, vacuum filtration, vacuum inspection, vacuum freeze drying, vacuum coating, vacuum leak detection, vacuum packaging, vacuum adsorption, etc.



R-4SN



R-8SN



R-16SN



Oil level indication



Connector and adapter



Pumping rate curve

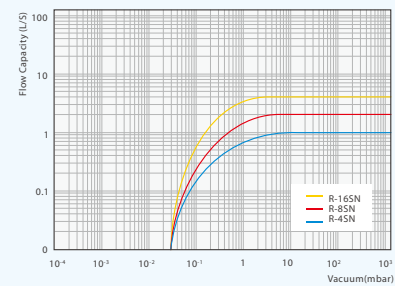

Note: Above data is based on the 220V/50Hz instrument

Model / Specifications	R-4SN	R-8SN	R-16SN
Order No.	900101	900102	900104
Flow rate [m ³ /h] at atm. pressure	3	7.2	14.4
Flow rate [L/min] at atm. pressure	50	120	240
Ultimate vacuum [mbar abs.]	2.5 x 10 ⁻²	2.5 x 10 ⁻²	2.5 x 10 ⁻²
Max. Power P [W]	180	250	550
Motor speed [rpm]	1400	1400	1400
Hose connections of inlet	SAE 3/8" / UNF 7/16-20	SAE 3/8" / UNF 7/16-20	DN25KF
Hose connections of outlet	DN25KF	DN25KF	DN25KF
Oil filling volume [L]	0.25	0.33	1
IP code	IP40	IP40	IP40
Noise [dB]	54	54	54
Dimensions W x D x H [mm]	314×280×122	314×288×142	512×300×158
Weight [kg]	9	11	22
Power supply	220V/50Hz	220V/50Hz	220V/50Hz



Features

- > Compact structure
- > Very good sealing
- > No returning throughput
- > Oil-spout prevention
- > Low noise
- > Oil-observation window
- > Handle for easy transportation
- > High flow rate
- > Low and stable ultimate vacuum
- > High evaporation resistance
- > Comparatively high chemical resistance
- > High longevity
- > Low maintenance rate
- > Low oil mist
- > Gas ballast valve
- > Overcurrent protection

Application

- > Vacuum distillation
- > Vacuum filtration
- > Vacuum testing
- > Vacuum freeze drying
- > Vacuum plating
- > Leak detection
- > Vacuum packaging
- > Vacuum sorption
- > As a backing pump for turbo-molecular pumps or diffusion pumps

Pumping rate curve

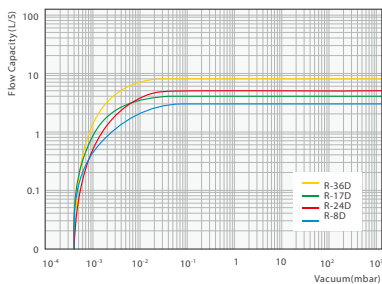

Note: Above data is based on the 220V/50Hz instrument

Model / Specifications	R-8D	R-17D	R-24D	R-36D
Order No.	900111	900112	900025	900035
Flow rate [m ³ /h] at atm. pressure	10.8	16.8	21.6	32.4
Flow rate [L/min] at atm. pressure	180	280	360	540
Ultimate vacuum [mbar abs.]	4.0 x10 ⁻⁴	4.0 x10 ⁻⁴	4.0 x10 ⁻⁴	4.0 x10 ⁻⁴
Max. Power P [W]	550	750	750	1100
Motor speed [rpm]	1400	1400	1400	1400
Hose connections of inlet	DN25KF	DN25KF	DN25KF	DN25KF
Hose connections of outlet	DN25KF	DN25KF	DN25KF	DN25KF
Oil filling volume [L]	1.1	1.4	1.9	2.1
IP code	IP44	IP44	IP44	IP44
Noise [dB]	54	54	56	56
Dimensions W x D x H [mm]	485 x 252 x 165	510 x 252 x 165	570 x 288 x 205	600 x 288 x 205
Weight [kg]	29	31	37	39
Power supply	220V/50Hz	220V/50Hz	220V/50Hz	220V/50Hz

Accessories for Rotary Vane Vacuum Pumps

Oil Mist Filter

The gas pumping out from the outlet often has some oil mist, which will effect the ambient, and sometimes is harmful. Chemvak's exhaust filter can almost stop all the oil mist and let it flow back to the pump and can reduce noise as well.

Name	Suitable for	Order No.
Oil mist trap	R-4SN, R-8SN (Direct connection, outlet DN25KF)	900101-1
Oil mist trap	R-16SN, R-8D, R-17D, R-24D, R-36D (Direct connection, outlet DN25KF)	900111-1



Condensate Separator, Dust Filter

Name	Suitable for	Order No.
Filter element for oil mist trap	Replacement for 900111-1 oil mist trap	900111-2
Condensate separator	R-16SN, R-8D, R-17D, R-24D, R-36D	900111-3
Dust filter	R-16SN, R-8D, R-17D, R-24D, R-36D	900111-4



Dust Filter

Adapter

Name	Description	Order No.
Adpter	Barbed fitting for tubing 8mm ID, 3/8 SAE. Suitable for R-4SN / R-8SN	168900-82
Adpter	Barbed fitting for tubing 10mm ID, 3/8 SAE. Suitable for R-4SN / R-8SN	168900-83
Adpter	Barbed fitting for tubing 12mm ID, 3/8 SAE. Suitable for R-4SN / R-8SN	168900-84

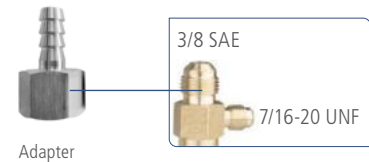

Adapter

Flange adppter

Name	Description	Order No.
Flange adppter	Barbed fitting for tubing 8mm ID, KF25. Suitable for R-16SN, R-8D, R-17D, R-24D, R-36D	168900-08
Flange adppter	Barbed fitting for tubing 10mm ID, KF25. Suitable for R-16SN, R-8D, R-17D, R-24D, R-36D	168900-10
Flange adppter	Barbed fitting for tubing 12mm ID, KF25. Suitable for R-16SN, R-8D, R-17D, R-24D, R-36D	168900-12
Flange adppter	Barbed fitting for tubing 19mm ID, KF25. Suitable for R-16SN, R-8D, R-17D, R-24D, R-36D	168900-19
Flange adppter	Barbed fitting for tubing 25mm ID, KF25. Suitable for R-16SN, R-8D, R-17D, R-24D, R-36D	168900-25

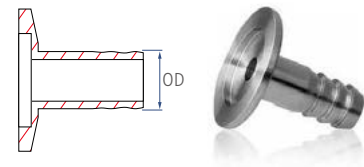

Adapter

No.	Description	Order No.
①	Connector, KF16 to KF25, suitable for R-16SN, R-8D, R-17D, R-24D, R-36D	DVM150BJFL001
②	Connector, KF16 to threaded connector, suitable for R-4SN, R-8SN	DVM150BJFL002
③	KF16 flange clamp	BJFL003
④	KF25 flange clamp	BJFL004

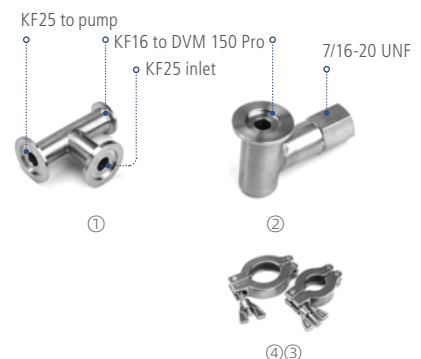

Highspeed Pump Oil

ChemVak highspeed oil employs a very good lubricant function, and has a high emulsion and oxidation resistance. It helps maintain the longevity of the system and reach a stable ultimate vacuum.

	Order No.
500 mL	900100-04
1 L	900100-05
5 L	900100-02
10 L	900100-03



Thick Vacuum Tubing

Thick rubber tube, which can be used for very high-vacuum applications

Inner Diameter(mm)	Thickness (mm)	Length(m)	Order No.
8	5	1	22690-06
10	9.5	1	22690-11
12	9.5	1	22690-13
19	9.5	1	22690-21
25	9.5	1	22690-26

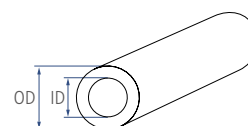

Krytox LVP High-Vacuum Grease

Very low vapor pressure, highly inert, nonflammable grease. The grease for high vacuum systems. Superior performance in laboratory and pilot plant equipment, as a lubricant and sealant for stopcocks, valves, fittings and O-Rings operating at high vacuum or in hostile environments.

	Order No.
50g	8116-10



Digital Vacuum Meter

- > Designed for rotary vane pumps
- > Compact design, flange connector, strong tightness
- > TFT high brightness screen, easy for observation from multiple angles or long distance
- > Can be directly connected to vacuum pump by flange connection, material for contact parts of the gas is stainless steel
- > Connection KF16

Model	Display resolution	Testing range	Material of sensor	Size of the meter	Order No.
DVM150Pro	0.001mbar	0.001-9.999mbar	PIRANI	100*65*55mm	15060-02



• KF16 Flange adapter

DVM150Pro

Electrical Aspirator Pump

Portable dual-channel, water-jet aspirator pump.

VE-11 creates a vacuum using an aspirator pump that is dependent on the vapor pressure of water. Ideal for rotary vacuum evaporators, decompressing distillatories, vacuum dryers, and vacuum filtering units.

Features

- > Economic use of resources
- > High flow rate up to 36 L/min
- > Vacuum can be regulated between 20 mmHg and 74 mmHg
- > Employs two water flow and gas suction devices, a check valve, and an upstream prevention device
- > Housing is made of PP to enhance longevity
- > Small amounts of liquid in the machine don't harm the system. Built-in circulating pump and water tank makes this unit portable and eliminates water waste.
- > Circulating pump continuously forces water quietly across a set of aspirators, and therefore clean and efficient.
- > Included (2) metal aspirators to create a vacuum with a built-in check valve to prevent backflow of water into the aspirator pump.
- > Submerged parts: 304 stainless steel, polypropylene silicone, and nickel-coated brass.
- > Tank features a drain port and spigot for easy water changes.
- > Unlike other vacuum pumps the VE-11 can suck a little bit of solvent. (water)



Included Accessories

- > Tank / Aspirating pump / Tank closure.
- > Two aspirators.
- > Two ø6mm (0.02") silicone rubber tube 20cm (0.7 ft) in length and an additional ø6mm (0.02") silicone rubber tube 100cm (3.3 ft) in length.

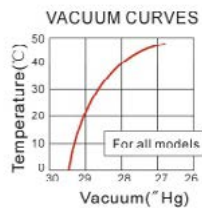

VE-11

Vacuum gauge / regulator are optional

Specifications & Ordering Information

Model	VE-11	
Max. Flow Rate	36 L/min (18 L/min*2)	
Water Tank Capacity(L)	9.5 L	
Motor Power(W)	150 W	
Material (Water Tank)	Polypropylene	
Dimensions	Water Tank(WxDxH mm)	298 x 210 x 227
	Case(WxDxH mm)	330 x 265 x 390
	Absorption nozzle (mm)	Ø9.5 x 2
	Overflow nozzle (mm)	Ø17
Safety Devices	Fuse, check valve, overheat protection	
Weight (kg)	5.7	
Order No.	900701	

Application Area

- > Filtration
- > Distillation
- > Rotary evaporation



Vacuum Gauge / Regulator (Option)

Optional Accessories

- > Vacuum gauge / regulator: to monitor and control the vacuum pressure. (between 0.0267~0.0998MPa / 7.9~29.5" Hg)
- > Cooling coil: to prevent vacuum from decreasing due to temperature increase.

Accessories

Description	Order No.
Vacuum Gauge / Regulator	900701-1
VC-10 Cooling Coil	900701-2
ET-02 Aspirator	900701-3



VC-10 Cooling Coil



ET-02 Aspirator